



Duotronic® Horns and Sirens

High dB, Electronic Sound

5520 & 5521 Series

FEATURES

- > 114 dB audible signal
- > 5520 Series is weatherproofed by adding 349 back box
- > 5521 Series is weatherproof as supplied
- > Horn and siren or horn models
- > Easy Adaptaplate installation

AGENCY APPROVALS

- > UL 464 Listed
- > FM Approved Audible Notification Appliances Standard 3151-3152

SPECIFICATIONS

- > Horn frequency - 1.1KHz
- > Siren frequency - rises and falls from 600 to 1300 Hz every 3 seconds
- > Speaker swivels 180° horizontally and 90° vertically

The 5520 and 5521 Series are low current, high performance, high decibel signals which may be coded or used as a continuous alarm.

The 5520 Series is designed to function as either a horn or siren by setting an internal, tamper proof switch. The signal's universal Adaptaplate® mounts directly on walls, or on any single-gang opening. Adaptaplate speeds installation by allowing the installer to connect all field wiring to the plate and then finishing the installation by snapping the horn onto the plate. It also mounts to 3 1/4" (83mm), 3 1/2" (89mm), 4" (102mm) octagon, 4" (102mm) square boxes, or equivalent fittings. The signal may be weatherproofed using the Edwards Cat. No. 349 back box (see page 5-10).

The 5521 operates as a horn only. It is intended for weatherproof applications and must be mounted on the supplied Edwards Cat. No. 349 backbox (see page 5-10) using the universal Adaptaplate® (supplied).

The 5520 and 5521 Series are used for schools, factories, lumber yards, and other industrial and commercial installations. The horn signal is often used for timing, paging, and alarms. The siren signal is particularly suitable for high noise areas and often used for alerting an evacuation.



TECHNICAL INFORMATION

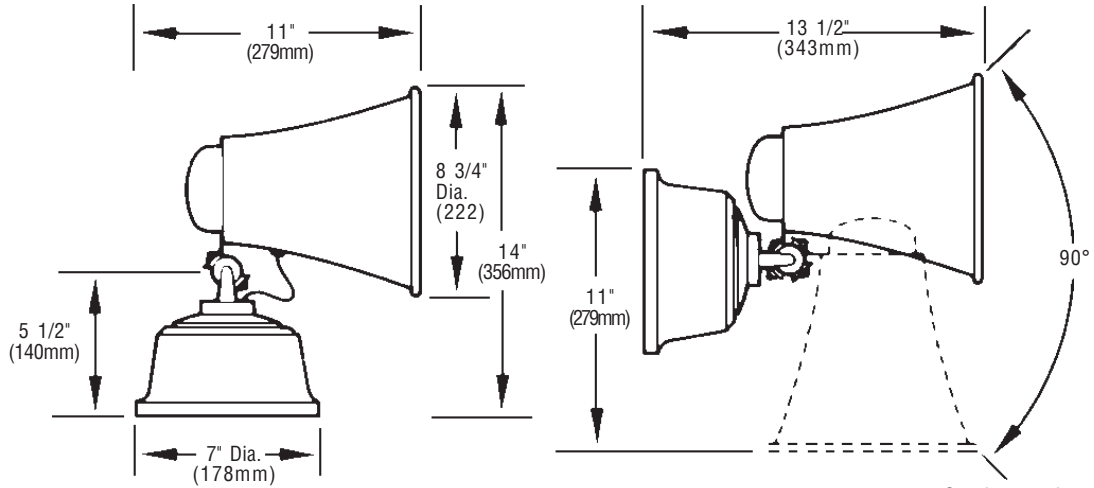

Speaker can be positioned anywhere within 90° vertically or 180° horizontally

5520 Series may be weatherproofed using Cat. No. 349 back box (purchased separately.)
5521 is supplied with Cat. No. 349 weatherproof back box

Cat. No.	Volts	Amps	VA	dB at 10 ft (3.05m)
5520-AS	12V AC 60 Hz	1.3	15.6	114 (Horn) 112 (Siren)
	12V DC	.7	8.4	
5520-AQ	24V AC 60 Hz	.85	20.4	
	24V DC	.35	8.4	
5520-N5	120V AC 60 Hz	.35	42	
5520-P1	125V DC	.1	12.5	
5520-R5*	240V AC 60 Hz	.1	24.0	
5521-S1	250V DC	.065	16.3	114 (Horn only)

*Uses separately mounted 598Y Transformer.